

OPERATION AND INSTALLATION INSTRUCTIONS FOR SMAC-SERIES SWIVEL CONNECTORS: 90-DEGREE & STRAIGHT-THROUGH

WARNING: This swivel connector contains a mechanical seal that will eventually leak product. Before leakage occurs, either replace the swivel with a new one or replace all seal components as per the instructions contained in this sheet. Conduct periodic leakage test with approved electronic leak detector. Do not use indoors-for outdoor use only. Your swivel connector contains a highly advanced mechanical seal designed for continuous rotation at 350 psi. Factory testing as per the U.L.-567 Standard involves an endurance test, deformation test, abuse test, hydrostatic strength test, electrical continuity test, and external leakage test.

FULL-CIRCLE swivels do not require any lubrication. They are fitted with a sealed radial contact ball bearing that supports the rotating portion of the swivel. Do not attempt to push grease or other lubricant into the swivel. The pressure relief fitting on the swivel main housing is designed as a point of leakage, in the event the internal mechanical seal is damaged. Should leakage develop, pushing grease into the swivel will not stop the leak. Instead, replace with a seal kit as outlined in these instructions.

To ensure that the ball bearing is protected from the liquid flowing through the swivel, a mechanical seal is used. The SUPERSEAL is designed to rotate at one-half the swivel speed. The seal ring floats between two metallic seal faces and seals on both sides.

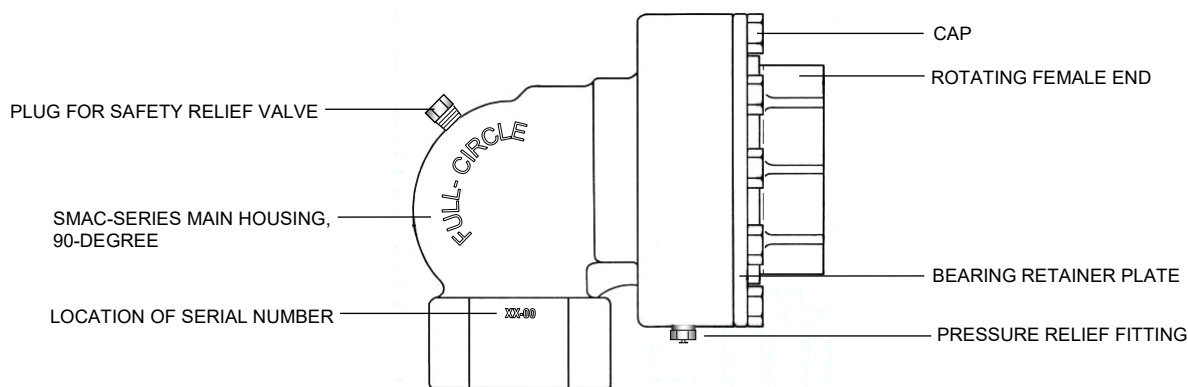

figure 1: SMAC-SERIES 90° SWIVEL JOINT
(main housing varies depending on swivel
model number)

INSTALLATION – HOSE REEL APPLICATION

For HOSE REEL INSTALLATION, the rotating female end of the swivel should be attached to the hose reel (see figure 1). A FLEX-CONNECTOR should be installed on the stationary female end. The FLEX-CONNECTOR will ensure that severe misalignment problems will not adversely affect the ball bearing in the swivel.

Once installed, there is no break-in period required. HOWEVER, if the SMAC-SERIES swivel is used to replace another brand, the brake on the hose reel may have to be adjusted. This is because the SMAC-SERIES swivel may rotate easier than other makes. CAUTION: If the hose reel brake is not adjusted, the hose reel may wind-up faster than what you are used to. BE CAREFUL.

INSTALLATION – STATIONARY BULK-HEAD LOADING/OFF-LOADING APPLICATION

For loading/off-loading installation, the SMAC-SERIES swivel can be used for “sweep” movement of hose (see figure 2). Note that the SMAC-SERIES swivel is installed “upside down” for this application with the rotating female end connected to the stationary pipe. This allows for wide sweeping movement of the hose.

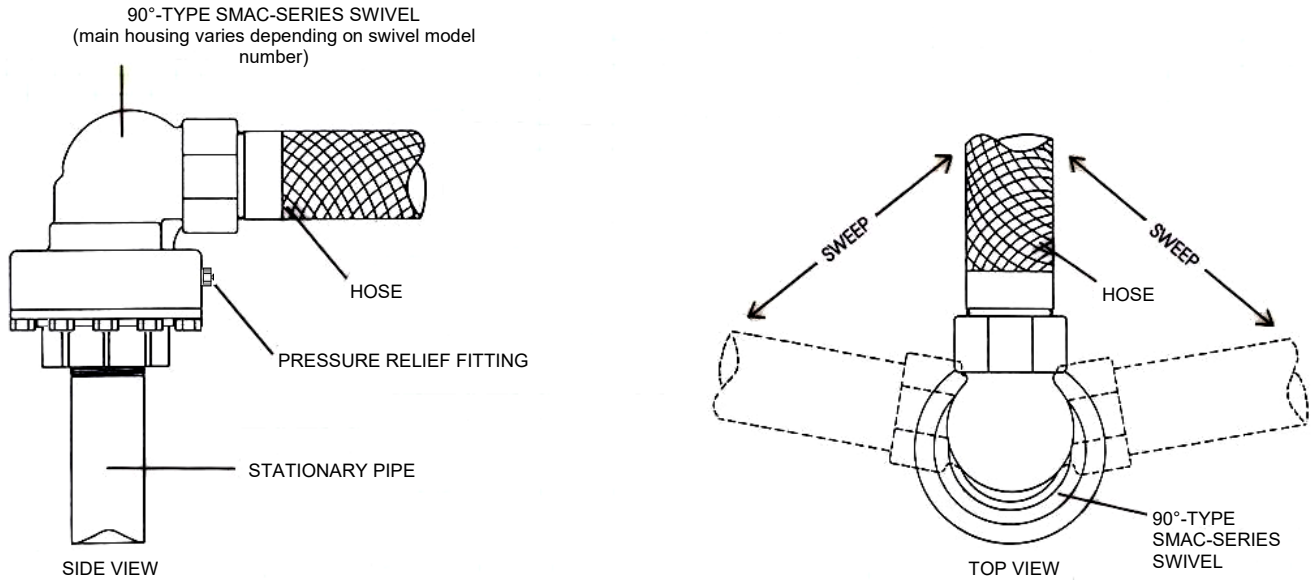

figure 2: STATIONARY LOADING/OFF-LOADING APPLICATION

REPAIR PROCEDURE

Should a repair become necessary, all internal parts should be replaced (see figure 3). ONLY REPAIR PARTS MANUFACTURED BY FULL-CIRCLE MUST BE USED. NEVER INSTALL PARTS MANUFACTURED BY OTHER BRANDS.

To accomplish a repair, the following procedure should be followed:

- 1.) Ensure that the “system” has been properly depressurized.
- 2.) Remove the swivel from the pipework and place it in a VICE with the rotating female end facing UP.
- 3.) Remove the screws that hold the bearing retainer plate onto the swivel body and remove the bearing retainer plate.
- 4.) Remove the rotating female end by pulling it out of the swivel body. The ball-bearing is pressed onto the rotating female end so it will come out also.
- 5.) Looking into the swivel body, you will see the seal ring. Remove the seal ring.
- 6.) The next part to come out is the stationary seal. There is an o-ring on the outside diameter of the stationary seal that you cannot see. This o-ring applies pressure around the stationary seal that makes it somewhat difficult to pull the stationary seal out.
- 7.) Now remove the spring.

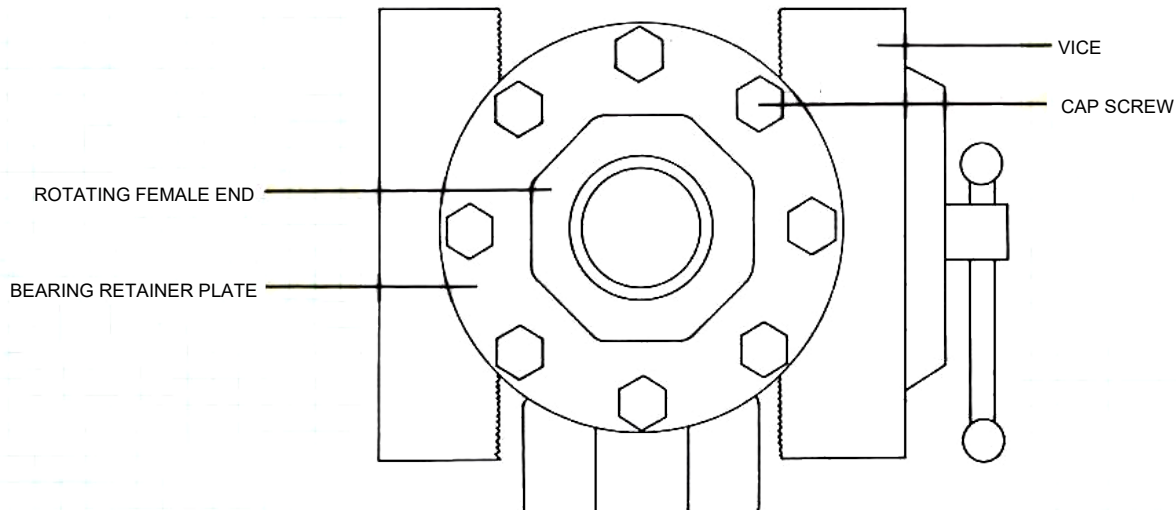

figure 3: REPAIR PROCEDURE
(main housing varies depending on swivel model number)

INSTALLING NEW REPLACEMENT PARTS (see figures 4 & 5)

To ensure a satisfactory and SAFE repair, ALL parts in the swivel should be replaced. DO NOT REUSE OLD PARTS as serious leakage may result. The following procedure should be followed:

- 1.) Make sure that the inside of the swivel body is clean and free from all debris. Set in vise, face up.
- 2.) Install the rounded PVC fixture into the main housing, and slide the following over the fixture, as indicated in steps "3" through "5".
- 3.) Install the spring spacer, then the spring. For all models except the 1-1/2 and 2-inch swivels, the large end of the spring MUST be installed first.
- 4.) Install the stationary seal. Make sure that the o-ring is installed on the stationary seal. The stationary seal has a lapped face on one side that seals against the seal ring. This lapped face should be facing up. It is important that the seal face be clean. AVOID touching the lapped face with your hands. Push the stationary seal into the swivel body with the two pins aligned with the half-moon grooves in the swivel body. Push the stationary seal all the way into the swivel body until it engages the spring.
- 5.) Now install the seal ring. The seal ring is lapped on both faces and either face can be installed facing up. AVOID touching either face with your hands to ensure that contaminants do not touch the lapped seal faces. Center the seal ring on the stationary seal by laying the seal ring on top of the stationary seal so that the centerline of the seal ring is the same as the centerline of the valve body. Use of the fixture will align the seal ring properly.

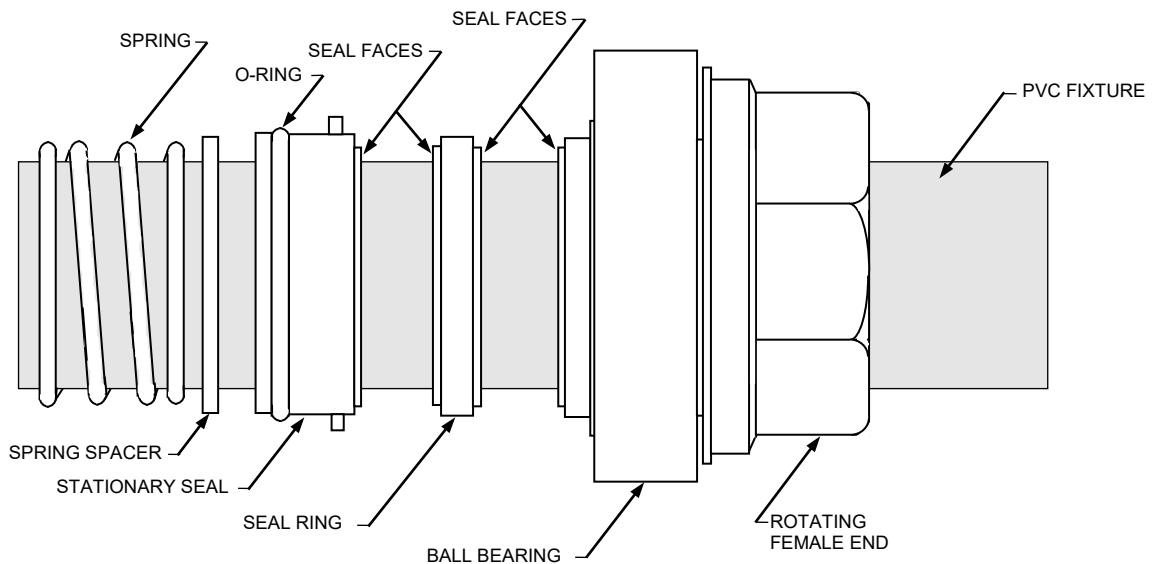

figure 4: SEAL COMPONENTS

- 6.) Now place the rotating female end with the ball bearing into the swivel body. The rotating female end contains a lapped seal face on the end. AVOID touching this seal face to ensure that contaminants do not touch the lapped seal face. With hand pressure, press the rotating female end into the swivel body until the ball bearing is flush with the top of the swivel body. At this point, the spring will exert some pressure. While holding down the rotating female end, install the bearing retainer plate. DO NOT RELIEVE PRESSURE WHILE SCREWING-ON THE BEARING RETAINER PLATE AS DAMAGE TO THE SEAL COMPONENTS WILL RESULT. Remove the PVC fixture, carefully pulling it out.
- 7.) Now rotate the swivel once or twice ONLY to ensure it is rotating smoothly.
- 8.) Install as recommended previously.

Should leakage occur after the repair procedure, disassemble as outlined above and carefully check the condition of the o-ring on the stationary seal as well as all seal faces for contamination or damage. Replace parts if damage is found and reassemble as outlined above.

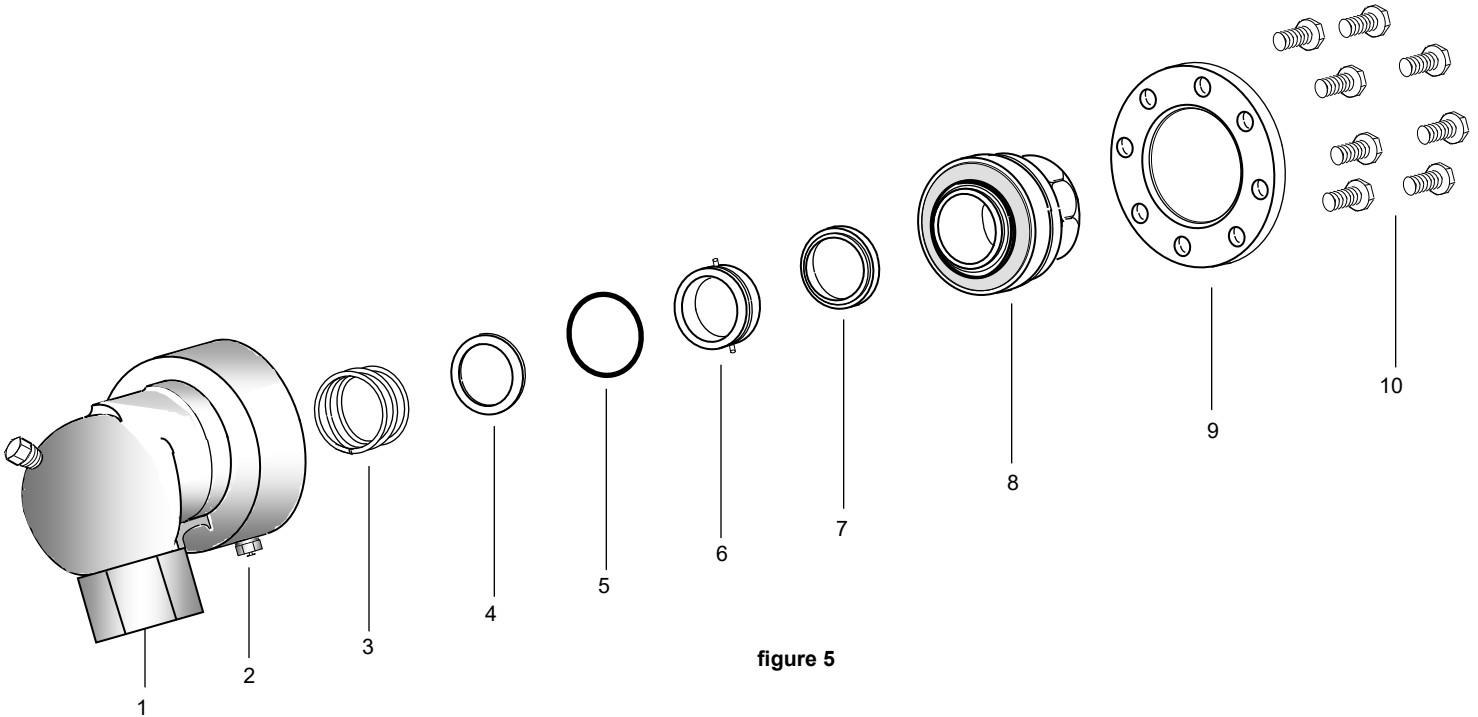

figure 5

- 1 – MAIN HOUSING
(ILLUSTRATED SWIVEL BODY IS THE 90-DEGREE TYPE;
STRAIGHT-THROUGH CONFIGURATIONS AND SS MODELS
NOT SHOWN ARE ALSO AVAILABLE).
- 2 – PRESSURE RELIEF FITTING
- 3 – SPRING
- 4 – SPACER
- 5 – O-RING FOR STATIONARY SEAL (STATIC O-RING)
- 6 – STATIONARY SEAL
- 7 – SEAL RING
- 8 – ROTATING FEMALE END
- 9 – BEARING RETAINER PLATE
- 10- CAP SCREWS

Operating Parameters:

U.L. Temperature Range: -40 degrees F to +150 degrees F

EU/UK Temperature Range: -20 degrees C to +40 degrees C

U.L. Maximum Working Pressure: 350 psi for LPG, 400 psi for NH₃, 50 psi for Flammables.

Maximum Allowable Pressure: 25 bar.

Maximum Hydrostatic Test Pressure: 2000 psi.

Maximum Rotational Speed: 100 RPM.

Fluid Compatibility: For SMAC-series: LN and CR-type for LPG/Natural Gas. N-type for Anhydrous Ammonia, FC-type for flammable liquids. SS type for LPG.

Compliance: UL 567, Pressure Equipment Directive, Pressure Equipment Safety Regulations (PE(S)R) 2016 Amended by the EU Exit Document 2019 #696 Schedule 24, Machinery Directive, Supply of Machinery (Safety) Regulations 2008, ATEX Directive, Equipment and Protective Systems Intended for Use in Potentially Explosive Atmospheres Regulations 2016 (UKEX) . Relative to the Pressure Equipment Directive for SMAC-type 1-1/4 through 2-inch pipe sizes (DN32 through DN50), product subject to monitoring of final assessment by Notified Body TÜV SÜD Industrie Service GmbH. Relative to the PE(S)R, product is subject to monitoring and final assessment by Approved Body TÜV SUD BABT. This product is Category II. Conformity assessment utilizes module A2.

ATEX/UKEX: Product assessed for Group II, Category 3, EPL Gc, Gas. T6=surface temp. not to exceed 85° C.

Permanent Product Marking: Serial number, year of mfg., pipe size for DN32 through DN50, model number, company name. All other pertinent information is contained on firmly affixed label plates attached to the product.

FULL-CIRCLE, INC.

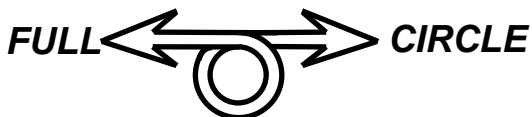

P.O. Box 276, Newbury Park, CA 91319 USA

1299 Lawrence Drive, Newbury Park, CA 91320 USA

Telephone: 805/498-2589 FAX: 805/499-2867 email: info@fullcircleswivels.com

web: www.FULLCIRCLESWIVELS.com