

# OPERATION AND INSTALLATION INSTRUCTIONS FOR VICTAULIC AND THREADED SMAC-SERIES SWIVEL JOINTS: 90-DEGREE & STRAIGHT-THROUGH FOR REFINED FUEL USE

**WARNING:** Make sure you have received the right swivel for your application. If the letters “FC” do not appear in the swivel model number, you have not received a swivel compatible for Refined Fuels. Do not install and use the swivel as leakage may result. Contact the distributor/OEM that supplied the swivel and make arrangements to receive the correct type.

FC-type Victaulic and threaded swivels for Refined Fuels are compatible with fuel oil, diesel fuel, gasoline/blends, lubricating oils, ethanol, methanol, ethanol/methanol blends, other alcohol blends, and manufactured/natural gas, within specific operating parameters, as shown on the last page. Victaulic type is not recommended for natural or liquefied gas use. If you are uncertain as to the suitability of an FC-type swivel for your application, please contact FULL-CIRCLE direct.

**FULL-CIRCLE swivels do not require any lubrication.** Do not attempt to push grease or other lubricant into the swivel. The pressure relief fitting on the swivel main housing is designed as a point of leakage, in the event the internal mechanical seal is damaged. Should leakage develop, pushing grease into the swivel will not stop the leak. Instead, replace with a seal kit as outlined in these instructions.

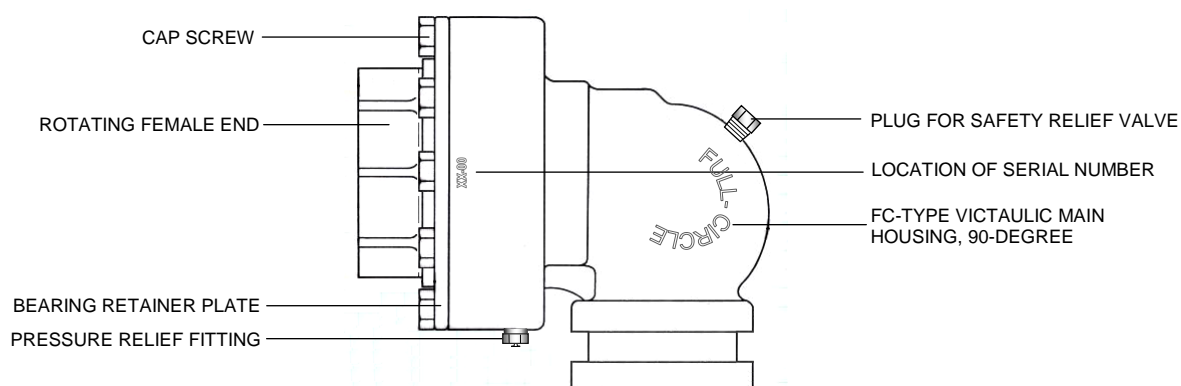

figure 1: FC-TYPE VICTAULIC SWIVEL JOINT

## INSTALLATION – HOSE REEL APPLICATION

For HOSE REEL INSTALLATION, the rotating female end of the swivel should be attached to the hose reel (see figure 1). A FLEX-CONNECTOR should be installed on the stationary Victaulic or threaded end. Use a suitable 2-inch Victaulic Fitting if required.

Once installed, there is no break-in period required. However, if the FC-type swivel is used to replace another brand, the brake on the hose reel may have to be adjusted. This is because the FC-type swivel may rotate easier than other makes. CAUTION: If the hose reel brake is not adjusted, the hose reel may wind-up faster than what you are used to. BE CAREFUL.

## INSTALLATION – STATIONARY BULK-HEAD LOADING/OFF-LOADING APPLICATION

For loading/off-loading installation, the SMAC-SERIES swivel can be used for “sweep” movement of hose (see figure 2). Note that the SMAC-SERIES swivel is installed “upside down” for this application with the rotating female end connected to the stationary pipe. This allows for wide sweeping movement of the hose. Victaulic type swivels are not recommended for this application.

FC-TYPE THREADED SWIVEL

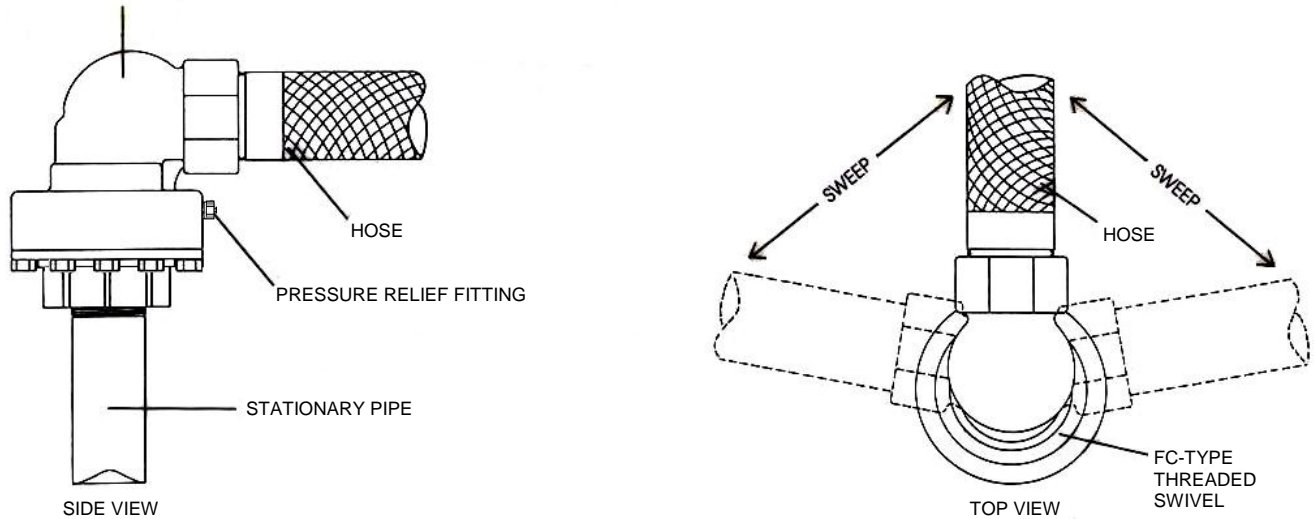

figure 2: STATIONARY LOADING/OFF-LOADING APPLICATION

## REPAIR PROCEDURE

Should a repair become necessary, all internal parts should be replaced (see figure 3).

To accomplish a repair, the following procedure should be followed:

- 1.) Ensure that the “system” has been properly depressurized.
- 2.) Remove the swivel from the pipework and place it in a VICE with the rotating female end facing UP.
- 3.) Remove the screws that hold the bearing retainer plate onto the swivel body and remove the bearing retainer plate.
- 4.) Remove the rotating female end by pulling it out of the swivel body. The ball-bearing is pressed onto the rotating female end so it will come out also.
- 5.) Looking into the swivel body, you will see the seal ring. Remove the seal ring.
- 6.) The next part to come out is the stationary seal. There is an o-ring on the outside diameter of the stationary seal that you cannot see. This o-ring applies pressure around the stationary seal that makes it somewhat difficult to pull the stationary seal out.
- 7.) Now remove the spring.

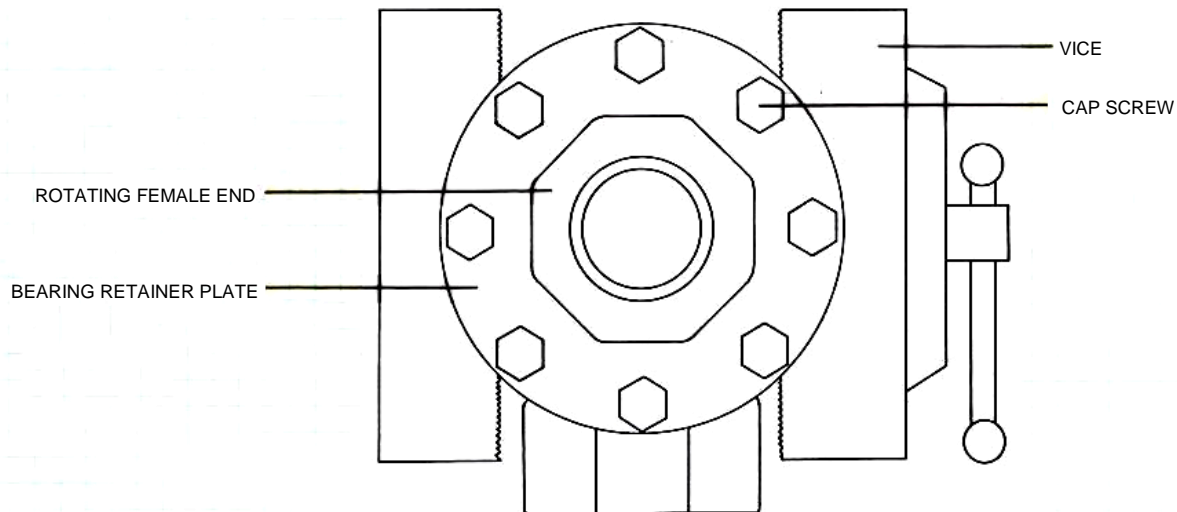

figure 3: REPAIR PROCEDURE

## INSTALLING NEW REPLACEMENT PARTS (see figures 4 & 5)

To ensure a satisfactory and SAFE repair, ALL parts in the swivel should be replaced. DO NOT REUSE OLD PARTS as serious leakage may result. The following procedure should be followed:

- 1.) Make sure that the inside of the swivel body is clean and free from all debris.
- 2.) Install the rounded PVC fixture into the main housing, and slide the following over the fixture, as indicated in steps "3" through "5".
- 3.) Install the spring spacer, then the spring. For all models except the 1-1/2 and 2-inch swivels, the large end of the spring MUST be installed first.
- 4.) Install the stationary seal. Make sure that the o-ring is installed on the stationary seal. The stationary seal has a lapped face on one side that seals against the seal ring. This lapped face should be facing up. It is important that the seal face be clean. AVOID touching the lapped face with your hands. Push the stationary seal into the swivel body with the two pins aligned with the half-moon grooves in the swivel body. Push the stationary seal all the way into the swivel body until it engages the spring.
- 5.) Now install the seal ring. The seal ring is lapped on both faces and either face can be installed facing up. AVOID touching either face with your hands to ensure that contaminants do not touch the lapped seal faces. Center the seal ring on the stationary seal by laying the seal ring on top of the stationary seal so that the centerline of the seal ring is the same as the centerline of the valve body.

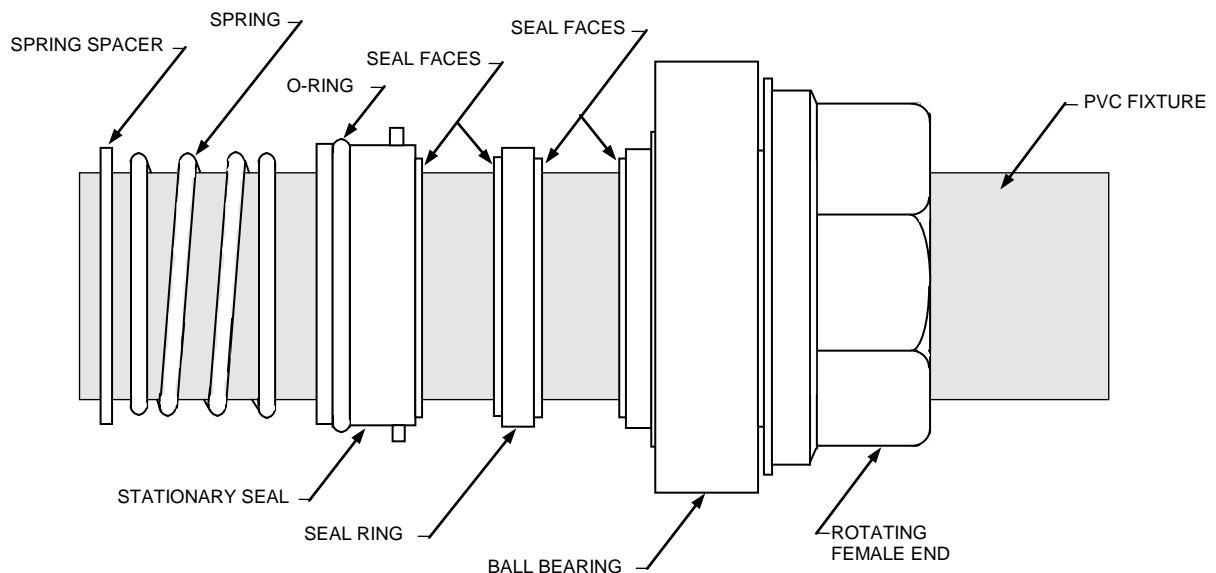

figure 4: SEAL COMPONENTS

- 6.) Now place the rotating female end with the ball bearing into the swivel body. The rotating female end contains a lapped seal face on the end. AVOID touching this seal face to ensure that contaminants do not touch the lapped seal face. With hand pressure, press the rotating female end into the swivel body until the ball bearing is flush with the top of the swivel body. At this point, the spring will exert some pressure. While holding down the rotating female end, install the bearing retainer plate. DO NOT RELIEVE PRESSURE WHILE SCREWING-ON THE BEARING RETAINER PLATE AS DAMAGE TO THE SEAL COMPONENTS WILL RESULT. Remove the PVC fixture.
- 7.) Now rotate the swivel once or twice ONLY to ensure it is rotating smoothly.
- 8.) Install as recommended previously.

Should leakage occur after the repair procedure, disassemble as outlined above and carefully check the condition of the o-ring on the stationary seal as well as all seal faces for contamination or damage. Replace parts if damage is found and reassemble as outlined above.

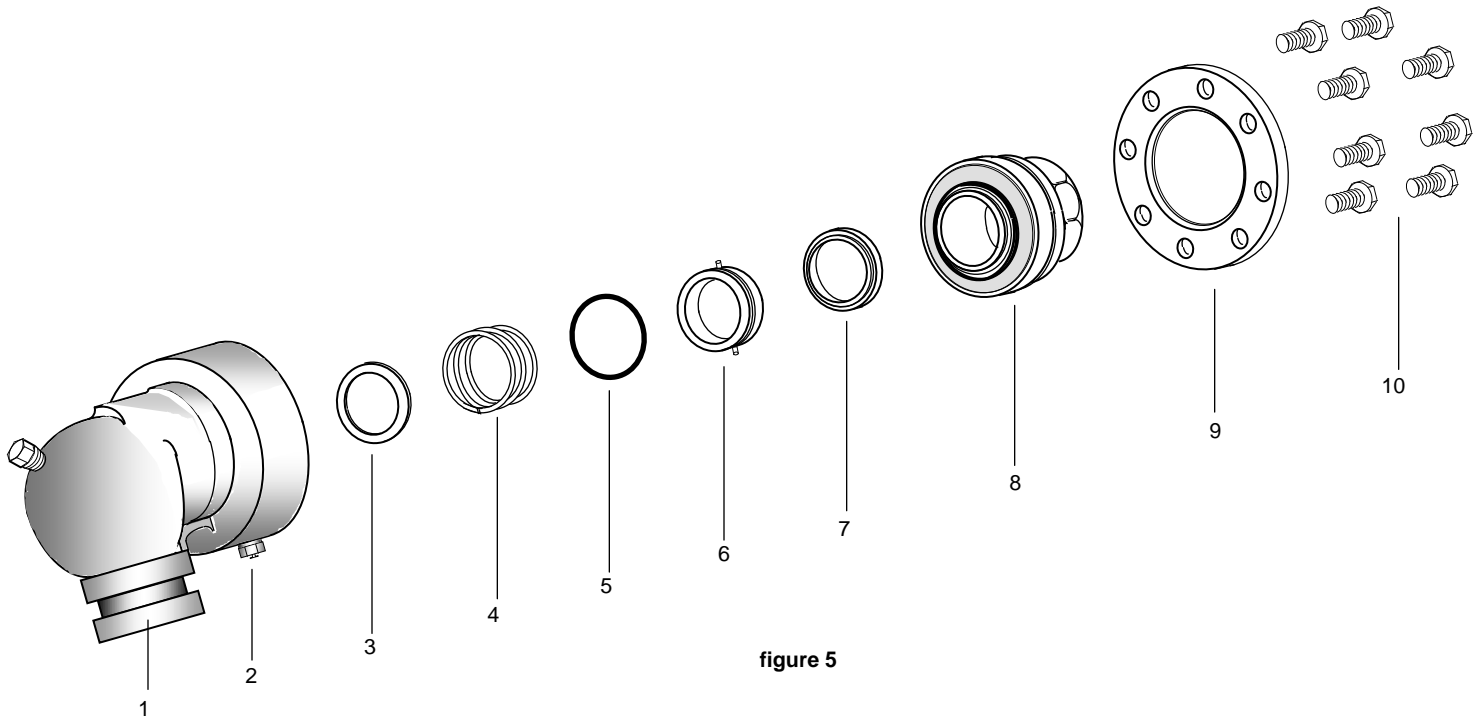

figure 5

- 1 – MAIN HOUSING  
(ILLUSTRATED SWIVEL BODY IS THE 90-DEGREE VICTAULIC TYPE; THREADED TYPES ARE AVAILABLE. STRAIGHT-THROUGH CONFIGURATIONS NOT SHOWN, EITHER AS “VICTAULIC” OR “THREADED”, ARE ALSO AVAILABLE).
- 2 – PRESSURE RELIEF FITTING
- 3 – SPACER
- 4 – SPRING
- 5 – O-RING FOR STATIONARY SEAL (STATIC O-RING)
- 6 – STATIONARY SEAL
- 7 – SEAL RING
- 8 – ROTATING FEMALE END
- 9 – BEARING RETAINER PLATE
- 10- CAP SCREWS

**Operating Parameters:**

**Minimum Temperature:** Minus 40 degrees F.

**Maximum Temperature:** Plus 140 degrees F.

**Maximum Working Pressure:** As high as 350 PSI; depends on fluid and application. Contact FULL-CIRCLE.

**Maximum Hydrostatic Test Pressure:** 2000 PSI.

**Maximum Rotational Speed:** 1000 RPM.

**Maximum Permissible Load:** Varies with speed; contact FULL-CIRCLE with application information.\*\*\*

**Fluid Compatibility:** Static o-ring is U.L. Recognized Compound for B, C, D, F, G, and J fluids covered under Gaskets and Seals (JMLU2) category, in U.L. Standard “UL 157”. FC-type swivels are not recommended for J fluids. LN-type swivels are recommended for J fluids. J fluids include LP-Gas.

**Applicable U.L. Standard:** UL 567.

\*\*\*Ball bearing has static load capacity of 6000 pounds. As rotational speed increases, the load capacity decreases.

**FULL-CIRCLE, INC.**

P.O. Box 276, Newbury Park, CA 91319 USA

1299 Lawrence Drive, Newbury Park, CA 91320 USA

Telephone: 805/498-2589 FAX: 805/499-2867 email: FULLCIRC92@aol.com

web: [www.FULLCIRCLESWIVELS.com](http://www.FULLCIRCLESWIVELS.com)

