

**READ THESE INSTRUCTIONS AND FAMILIARIZE YOURSELF WITH THIS PRODUCT BEFORE IT IS INSTALLED.**

**Installation/Operating Instructions for MA-20SLT Meter Bleed Flange**

The MA-20SLT meter bleed flange is designed to bolt onto the meter casing where the strainer screen flange is installed. The MA-20SLT is completely fabricated from Stainless Steel. It is not necessary to paint the MA-20SLT after installation. The MA-20SLT is a U.L. Recognized Component. The MA-20SLT will fit newer style ¾ and 1-inch Liquatech and Schlumberger meters, types LPM-102 and 4D-MD.

Once installed, the intended purpose of the MA-20SLT is to quickly and safely evacuate product from the meter so the strainer screen can be serviced. The MA-20SLT contains two o-ring seals that must be periodically replaced. Periodic replacement interval depends on several factors involving use conditions. Failure to replace damaged o-ring seals will result in leakage. Inspect o-ring seals at yearly intervals and replace if required.

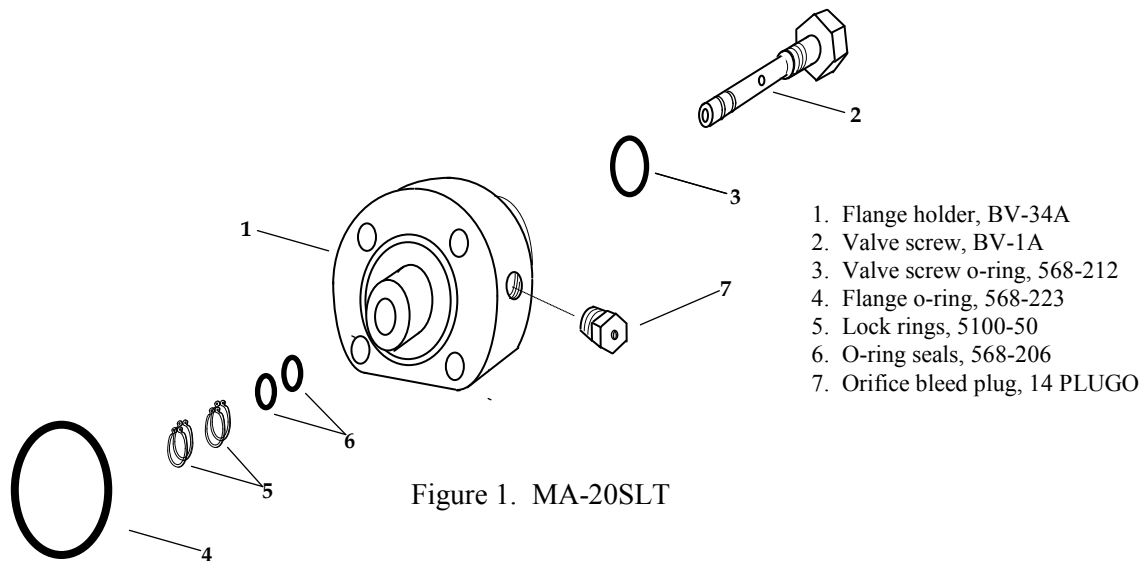

Figure 1. MA-20SLT

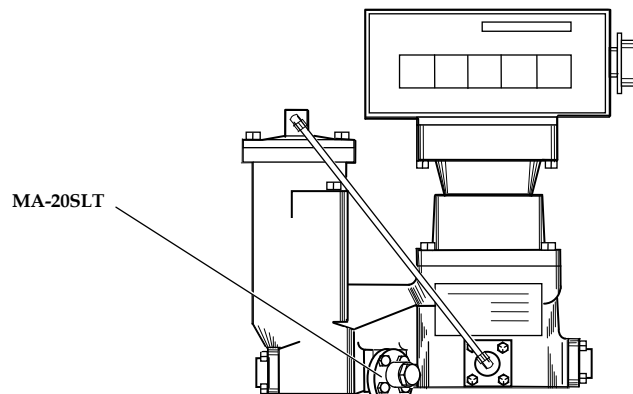

Figure 2. MA-20SLT installed on meter

**Installation on a meter: ONLY QUALIFIED AND PROPERLY TRAINED PERSONNEL SHOULD INSTALL THE MA-20SLT ONTO A METER**

- 1.) The meter must be safely valved-off and evacuated of all product. This procedure must be followed in accordance with the meter manufacturer's directions, your company policy, NFPA-58, and any other applicable Codes and Practices for the safe handling of LP-GAS.
- 2.) Once the meter is properly evacuated, remove the blind strainer flange from the meter casing. This may already have been accomplished during the meter blow-down procedure. Clean-up the area on the meter casing where the old flange was installed, and install the MA-20SLT in the same location, making sure the o-ring on the back of the MA-20SLT is firmly seated in its groove AND the valve screw is tightened or rotated clockwise as far as it will go. DO NOT reuse the old blind strainer flange cap screws as they are too short. Use the cap screws provided with the MA-20SLT. Tighten and torque the four cap screws to 15 ft-lbs. It is important that the condition of the cap screws is continually monitored every time the MA-20SLT is removed. Continual use of old cap screws may lead to eventual cap screw failure. Should one or more of the cap screws fail, product release may occur. Do not overtorque.
- 3.) By following the meter manufacturer's directions and company procedure, recharge the meter. Check to make sure there is no leakage coming from any part of the MA-20SLT. If there is leakage, do not proceed further; call us. If there is no leakage, proceed to test the MA-20SLT by unscrewing the valve screw in a counterclockwise fashion until product discharges from the bleed port on the side of the flange. If product also discharges from the front of the flange where the valve screw is, this indicates one of the o-ring seals is damaged and must be replaced. Call us for advice. Once product starts to discharge from the side bleed port, turn the valve screw in a clockwise manner until the discharge stops. Now tighten the valve screw with an appropriate socket wrench until the head of the valve screw is tightly secured to the bottom of the flange housing. Note the o-ring in the bottom of the flange housing. This o-ring is to keep contaminants from entering the thread area of the flange housing which may contribute to thread galling. Also, should the two primary seal o-rings fail, this o-ring will prevent leakage from discharging from the front of the MA-20SLT. Periodic checks should be conducted to make sure this o-ring is not damaged. If damage is noted, it should be replaced.

**Received on a new meter:**

Review steps 1.) through 3.), although step 3.) should be followed if the MA-20SLT was preinstalled on a new meter.

**Operation:**

Once installed, to service the meter strainer screen, the meter must be valved-off according to your company policy. To evacuate product in the meter, the MA-20SLT valve screw should be turned in a counterclockwise direction until product discharges from the bleed port. A ¼-inch plug with orifice is screwed into the bleed port. For maximum discharge, the plug can be removed. While turning the valve screw counterclockwise to bleed product, at some point the valve screw will stop. At this point, do not continue to turn the valve screw in a counterclockwise direction.

This is the maximum bleed position where two lock rings on the valve screw are contacting the backside of the flange body and preventing the valve screw from turning any more. Damage to the lock rings will result if the valve screw continues to be loosened beyond this maximum bleed position.

Once all product from the meter has been discharged, do not tighten the valve screw; leave it in the open position. Then, unscrew the four cap screws that hold the flange onto the meter casing and remove the MA-20SLT. To reinstall after the meter strainer screen has been serviced, clean the area on the meter where the MA-20SLT was installed, make sure the large o-ring on the backside of the MA-20SLT is firmly seated in its groove, inspect the four cap screws and replace if damaged, and tighten the cap screws that hold the MA-20SLT in place to 15 ft-lbs. The use of new cap screws is recommended. We only recommend plated Grade 5 heat treated type. Replace the ¼-inch plug with orifice if it was removed. Do not use a plug without the orifice.

Follow procedure 3.) under “Installation on a Meter” found in this manual to make sure the MA-20SLT is functioning properly.

### **O-ring Replacement:**

It is necessary to remove the MA-20SLT from the meter casing to replace the valve screw o-rings. Safely blow-down the meter as described in this manual under “Operation”. Then, loosen the four cap screws that hold the MA-20SLT onto the meter casing and remove the MA-20SLT. To remove and reinstall the valve screw o-rings, the following steps should be followed:

- 1.) Remove the valve screw lock rings. There are four of them. If lost, use only Stainless Steel lock rings. Always reassemble four lock rings. Never reassemble and use the MA-20SLT unless all four lock rings are in place.
- 2.) Remove the valve screw from the flange body by turning the valve screw counterclockwise. When disengaged from the last thread, pull the valve screw out.
- 3.) The two valve screw o-rings to be replaced are located in the flange body. Remove from their respective o-ring grooves by using a sharp instrument.
- 4.) Clean the inside of the hole in the flange body where the o-rings are located.
- 5.) Install two new o-rings in their respective o-ring grooves and lubricate with a Molybdenum based grease.
- 6.) Clean the valve screw and lubricate with Molybdenum based grease. Gently insert the valve screw into the flange body and turn clockwise to engage the threads. Tighten all the way, just hand tight. Replace all four lock rings. Then loosen by turning the valve screw counterclockwise. Then, tighten again, hand tight. Make sure there is no binding when turning the valve screw clockwise and counterclockwise.
- 7.) Check the condition of the o-ring that seals under the valve screw head and replace if it appears damaged. Also, check the condition of the large o-ring on the backside of the MA-20SLT. Replace if it is damaged or is worn flat.
- 8.) Reinstall the MA-20SLT following step 3.) under “Installation on a Meter” found in this manual.

## **WARNING:**

The first set of two lock rings on the valve screw acts as a stop when the valve screw is turned counterclockwise. Once the valve screw is backed out sufficiently, these two lock rings prevent the valve screw from unscrewing any further. In the event these two lock rings become damaged, the second set of lock rings at the end of the valve screw will prevent the valve screw from blowing out of the flange body under pressure. It is important that all four lock rings are in place and not damaged. Replace damaged lock rings and do not use the MA-20SLT if one or more lock rings is missing. If the valve screw is assembled into the flange body with no lock rings installed, the valve screw will blow out of the flange body when the system is charged. Serious injury may result if this occurs. Make sure that all four lock rings have been installed.

Do not use the MA-20SLT other than for its intended purpose as described in this manual.

Follow all safety guidelines for product evacuation as outlined in your company policies, NFPA-58, and other applicable Codes and Practices for the safe handling of LP-GAS.

Call us if you are uncertain how to safely use this product.

### **Maintenance:**

The MA-20SLT should become a part of any periodic leak detection/maintenance program utilized by your company. Make sure that periodic checks are performed to determine if leakage is emanating from the MA-20SLT. Do not use the MA-20SLT if leakage is detected. Replace all o-rings if they appear to be damaged or worn flat. Periodic replacement of all o-rings is recommended before leakage is observed.

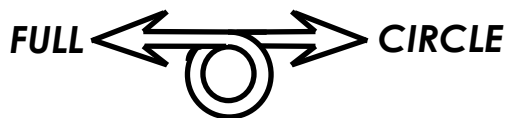

## **FULL-CIRCLE, INC.**

P.O. Box 276, Newbury Park, CA 91319 USA

1299 Lawrence Drive, Newbury Park, CA 91320 USA

Telephone: 805/498-2589 FAX: 805/499-2867 Web: [www.fullcircleswivels.com](http://www.fullcircleswivels.com)